



Adjustable Fuel Pressure Regulator

Part Number 61502 & 61503

Adjustable fuel pressure regulator installation instructions

1. With ½ tank of fuel, remove the gas cap to release pressure
2. Remove fuel pump fuse from fuse block, start engine and run until it quits. This will reduce fuel pressure, so that you won't spill as much when you remove the regulator.
3. Disconnect negative battery cable
4. Unsnap electrical connector for each injector. Use care to avoid damage to connector wire.
5. Remove the fuel rail hold down bolts
6. Gently pry and lift up on the fuel rail. This will pull the injectors up and out of the manifold.
NOTE: Make sure each injector still has its O-ring.
7. Remove the vacuum line connected to the stock fuel pressure regulator.
8. Loosen the nut connecting the fuel line to the regulator with a 15/16" wrench.
9. Loosen the Torx screw attaching the stock regulator to the fuel rail with a T30 torx driver.
10. Using a T25 torx driver remove the screw securing the clamp that holds the two fuel lines in place.
11. Remove stock fuel pressure regulator.
12. Attach the JET Adjustable Fuel Pressure regulator to the fuel rail and tighten with T30 torx driver.
13. Insert the fuel line o-ring into the regulator first, followed by the fuel return line.
14. Connect the fuel supply line by tightening the 15/16" nut. Place the fuel line into the lower half of the clamp assembly and loosely attach the top half.
15. With a o-ring installed on each injector, lower the fuel rail back into position over the manifold, and start each injector into its hole. Be careful not to pinch or damage the o-rings which could cause a fuel leak. Gently press down on fuel rail to fully seat all eight injectors. Injectors must be fully seated into the intake manifold to allow the fuel rail to seat properly on the top of the manifold.
16. Reinstall and tighten the (4) fuel rail hold down bolts.
17. Reinstall the remaining hardware in reverse order of disassembly
18. Recommended setting is 46 p.s.i.. To adjust, turn the adjusting screw (a small allen screw located inside the vacuum hose port on the regulator) clockwise to increase pressure, or counter-clockwise to decrease pressure. Once the pressure is set, slip the vacuum hose down onto the port, and you are ready to test.

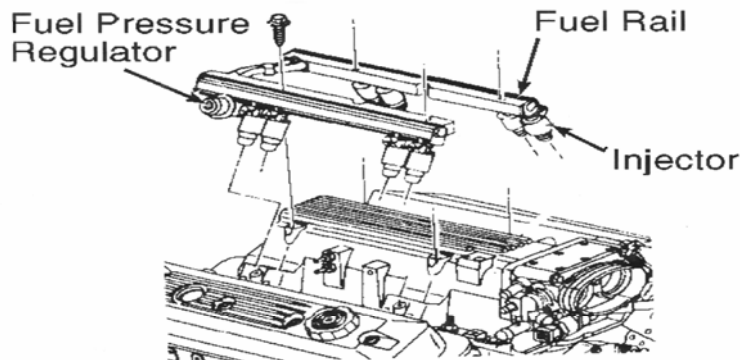

JET Performance Products, Inc.
17491 Apex Circle
Huntington Beach, Ca. 92647
714-848-5515